

ALL SYMONS COMPONENTS AND ACCESSORIES ARE DESIGNED WITH SAFETY AND PERFORMANCE IN MIND. THE APPLICATION NOTES ON THIS SHEET WILL HELP YOU ACHIEVE A SAFE AND PRODUCTIVE FORMING OPERATION. IT IS RECOMMENDED THAT ALL CONSTRUCTION PERSONNEL THOROUGHLY FAMILIARIZE THEMSELVES AND COMPLY WITH THE APPLICABLE INDUSTRY STANDARDS AND SAFE PRACTICES ESTABLISHED BY THE AMERICAN CONCRETE INSTITUTE, AMERICAN NATIONAL STANDARDS INSTITUTE, THE OCCUPATIONAL SAFETY AND HEALTH ADMINISTRATION, AND THE SCAFFOLDING AND SHORING INSTITUTE.

IMPORTANT:
ALL FORMING AND SHORING COMPONENTS MUST BE INSPECTED REGULARLY FOR DAMAGE OR EXCESSIVE WEAR. EQUIPMENT FOUND TO BE DAMAGED OR EXCESSIVELY WORN MUST BE REPLACED IMMEDIATELY.

STEEL-PLY SCAFFOLD BRACKET

- WARNING – IMPROPER ATTACHMENT OF WALKWAY BRACKETS AND WALKWAY COMPONENTS MAY RESULT IN SEVERE INJURY!
- DO NOT USE WALKWAY BRACKET AS A LIFTING BRACKET OR TE-OFF.
- ALLOWABLE LOAD ON WALKWAY BRACKET IS 500 LBS. @ 4:1 SAFETY FACTOR. WHEN THE WALKWAY BRACKETS ARE SPACED AT 6'-0" O/C, MAXIMUM ALLOWABLE APPLIED LOAD ON BRACKETS = 25 PSF. SECURE PLANKING TO WALKWAY BRACKETS.
- THE CONTRACTOR IS RESPONSIBLE FOR ENSURING THAT ALL WORKERS HAVE ADEQUATE FALL PROTECTION DURING FORMWORK ERECTION.
- THE CONTRACTOR IS RESPONSIBLE FOR DESIGNING AND SUPPLYING ANY ADDITIONAL COMPONENTS (PLANKING, GUARDRAILS, ETC.) REQUIRED TO CREATE A WORK PLATFORM WHICH MEETS OR EXCEEDS ALL APPLICABLE INDUSTRY STANDARDS.

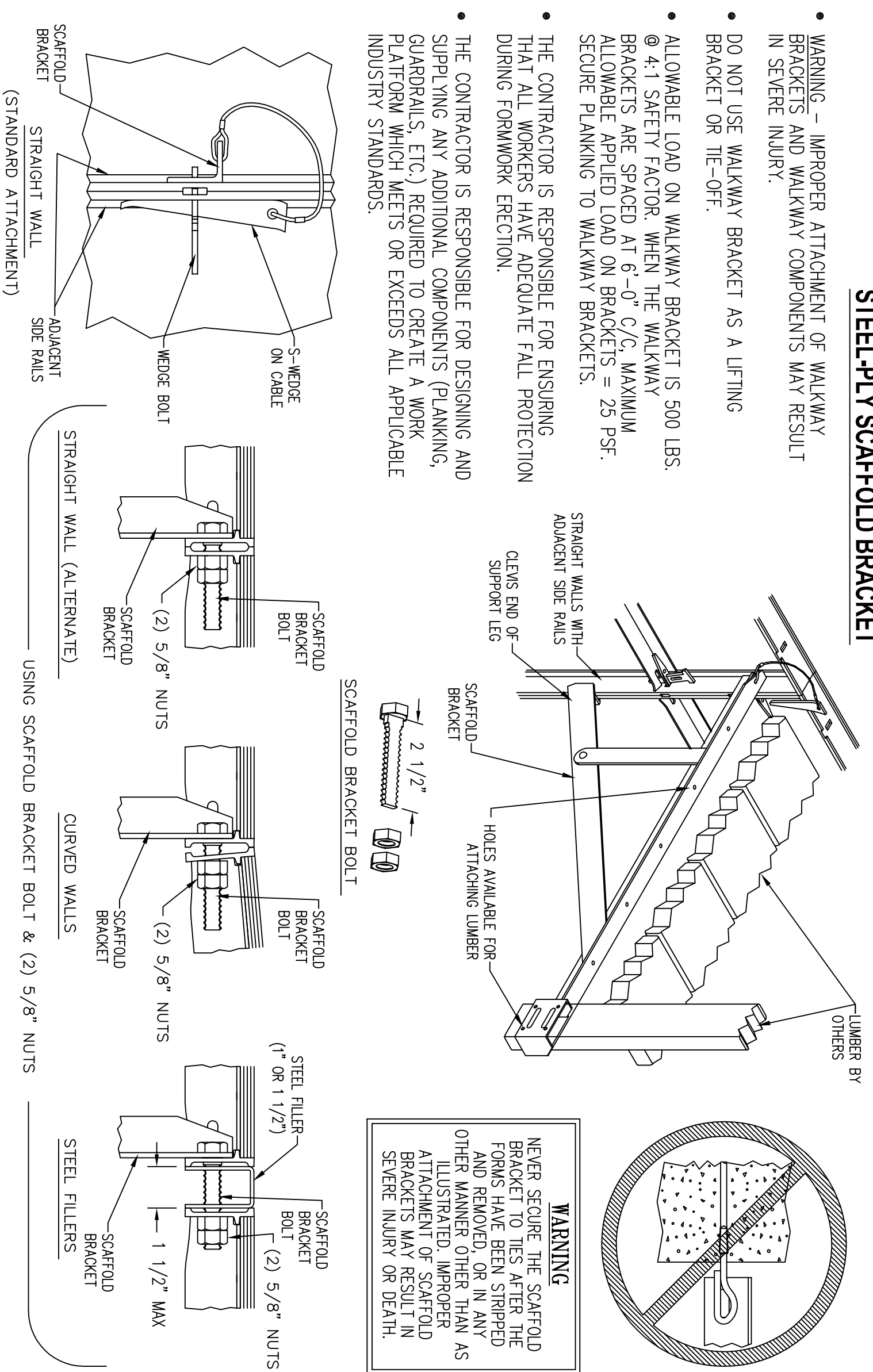

WARNING
NEVER SCORE THE SCAFFOLD BRACKET TO TIES AFTER THE FORMS HAVE BEEN STRIPPED AND REMOVED, OR IN ANY OTHER MANNER OTHER THAN AS ILLUSTRATED. IMPROPER BRACKET REMOVAL MAY RESULT IN SEVERE INJURY OR DEATH.

WARNING

1.) BRACING MUST BE IN PLACE WHILE SETTING FORMWORK AND REMAIN IN PLACE UNTIL FORMS ARE STRIPPED.
2.) CONTRACTOR IS TO INSURE THAT FORMWORK IS PROPERLY BRACED AND STABILIZED AGAINST WIND AND OTHER EXTERNAL FORCES.
STRIPPING AND REMOVAL OF GANG FORMS
1.) ATTACH THE CRANE RIGGING TO THE LIFTING BRACKETS AND SLOWLY TAKE UP THE SLACK IN THE RIGGING.
2.) SAFELY REMOVE ALL TIES, BRACES, AND ALIGNERS.
3.) BREAK THE BOND BETWEEN THE CONCRETE AND THE FORMS. DO NOT USE THE CRANE TO BREAK THE BOND.
4.) MOVE THE GANG FORM TO THE NEXT LOCATION.
5.) FULLY BRACE AND SECURE THE FORM BEFORE REMOVING CRANE RIGGING.

IMPORTANT:

BRACING / ALIGNERS

ALIGNERS
SYMONS TURNBUCKLE ALIGNERS AND ATTACHMENT PLATES ARE CONSIDERED ONLY AS ALIGNMENT DEVICES AND ARE NOT TO BE USED AS FORM BRACING.
WEAR EYE AND HEAD PROTECTION
SYMONS RECOMMENDS GLOVES, HARDHATS, SAFETY SHOES, AND SAFETY GLASSES BE WORN DURING ALL FORMING AND POURING OPERATIONS.

ATTACHMENT POINT FOR FALL PROTECTION EQUIPMENT

WHEN PROPERLY INSTALLED, BOTH THE SAFETY EYE AND QUICK HOOK HANDLE PROVIDE AN ATTACHMENT POINT FOR FALL PROTECTION EQUIPMENT THAT MEETS OR EXCEEDS THE LOAD REQUIREMENT UNDER FEDERAL OSHA STANDARD 1926.502(d)(14).
(NOTE – FORMS MUST BE ADEQUATELY BRACED BY THE CONTRACTOR TO RESIST THE RESULTANT LOADS – SEE GENERAL FORMING NOTE 2)

SAFETY EYE

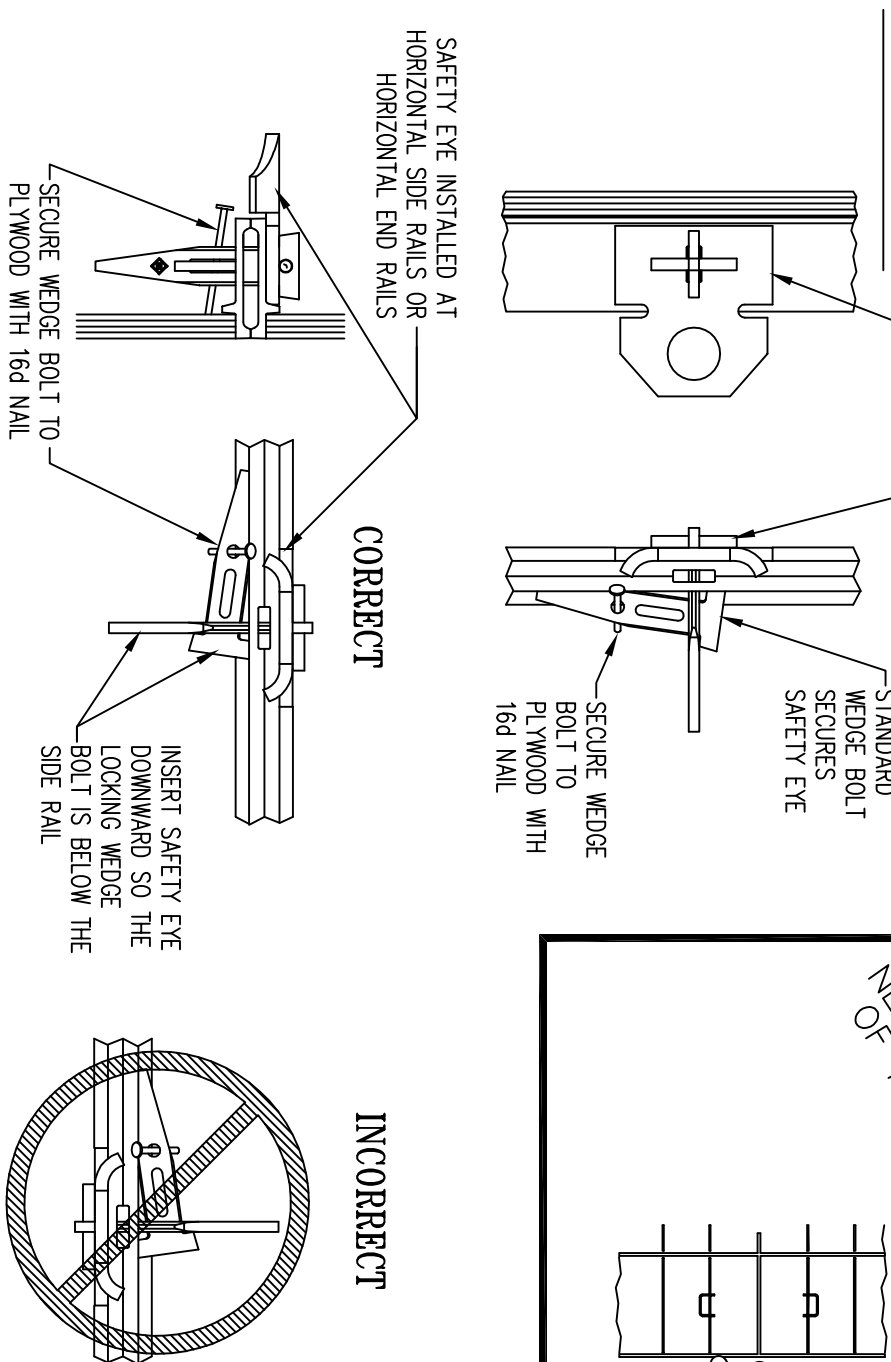

- A SAFETY EYE IS TO BE USED BY ONLY ONE PERSON AT ANY GIVEN TIME.
- ATTACH SAFETY BELT TO SAFETY EYE WHILE WORKING OR CLIMBING THE FORM.
- SAFETY EYES SHOULD BE SPACED AS REQUIRED TO ACHIEVE THE NECESSARY FALL PROTECTION ATTACHMENT POINTS.
- FORMWORK MUST BE ADEQUATELY BRACED BY THE CONTRACTOR TO RESIST THE RESULTANT LOADS.

WARNING
NEVER ATTACH THE SAFETY EYE AS A LIFT DEVICE IN ANY OR DEATH.
NEVER ATTACH THE SAFETY EYE TO A SINGLE HORIZONTAL STEEL-PLY SIDE OR END RAIL. SUCH ATTACHMENT POINTS WILL RESULT IN A LOOSE CONNECTION WHICH MAY RESULT IN SEVERE INJURY OR DEATH.

QUICK HOOK™ HANDLE

NO LONGER AVAILABLE ON NEW PRODUCTION PANELS

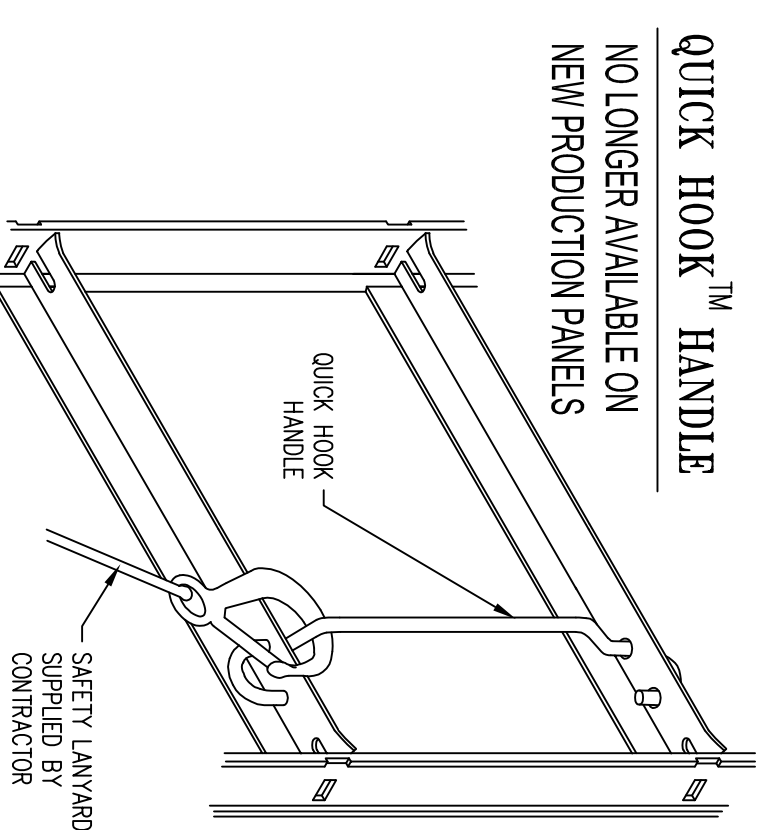

WHEN TIEING TO HANDLES, THE ONLY TO APPROVED THE OFF HANDLES

- A QUICK-HOOK HANDLE IS TO BE USED BY ONLY ONE PERSON AT ANY GIVEN TIME.
- ATTACH SAFETY BELT TO QUICK-HOOK HANDLE WHILE WORKING OR CLIMBING THE FORM.
- QUICK-HOOK HANDLES SHOULD BE SPACED AS REQUIRED TO PROVIDE THE NECESSARY FALL PROTECTION ATTACHMENT POINTS.
- FORMWORK MUST BE ADEQUATELY BRACED BY THE CONTRACTOR TO RESIST THE RESULTANT LOADS.

WARNING
NEVER ATTACH THE QUICK-HOOK HANDLE AS A LIFT BRACKET AS IT MAY BREAK AND CAUSE SEVERE INJURY OR DEATH.

ONE SIDED WALL APPLICATION

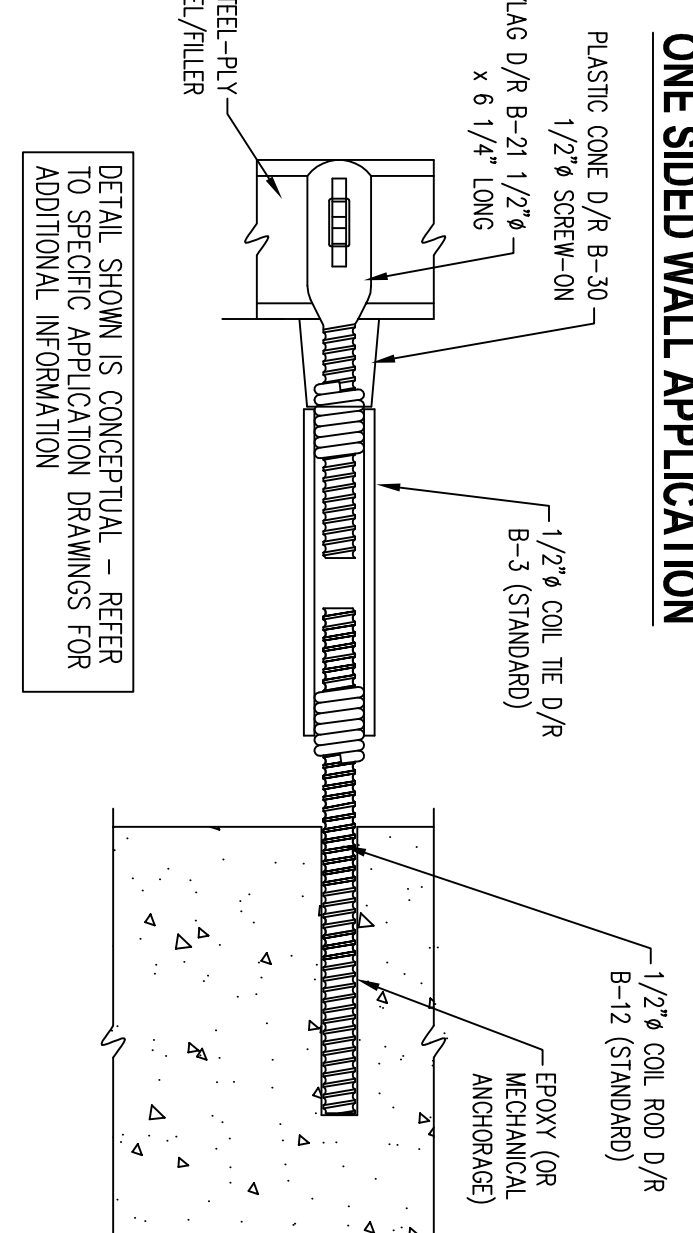

WEDGE BOLTS

A SUFFICIENTLY TIGHT WEDGE BOLT CONNECTION CAN BE ACHIEVED BY PUSHING DOWN ON THE HEAD OF THE VERTICAL WEDGE BOLT WITH ONE HAND WHILE STRIKING THE HEAD OF THE LATERAL WEDGE BOLT WITH A HAMMER. THE VERTICAL WEDGE BOLT WILL RESPOND DOWNWARD TO A TIGHT, SECURE POSITION.

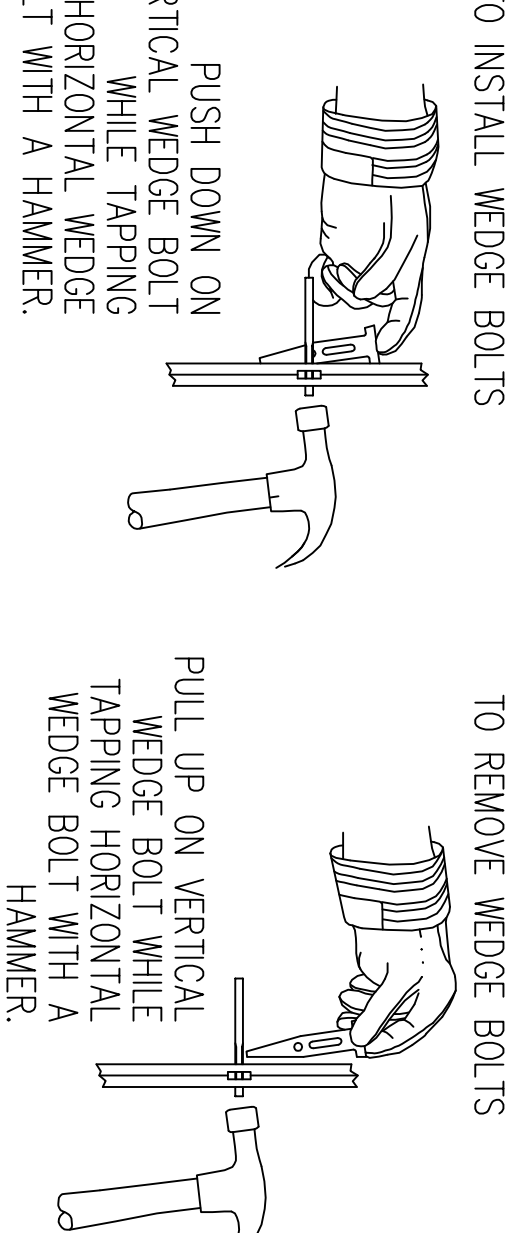

PANEL CARRYING HANDLES

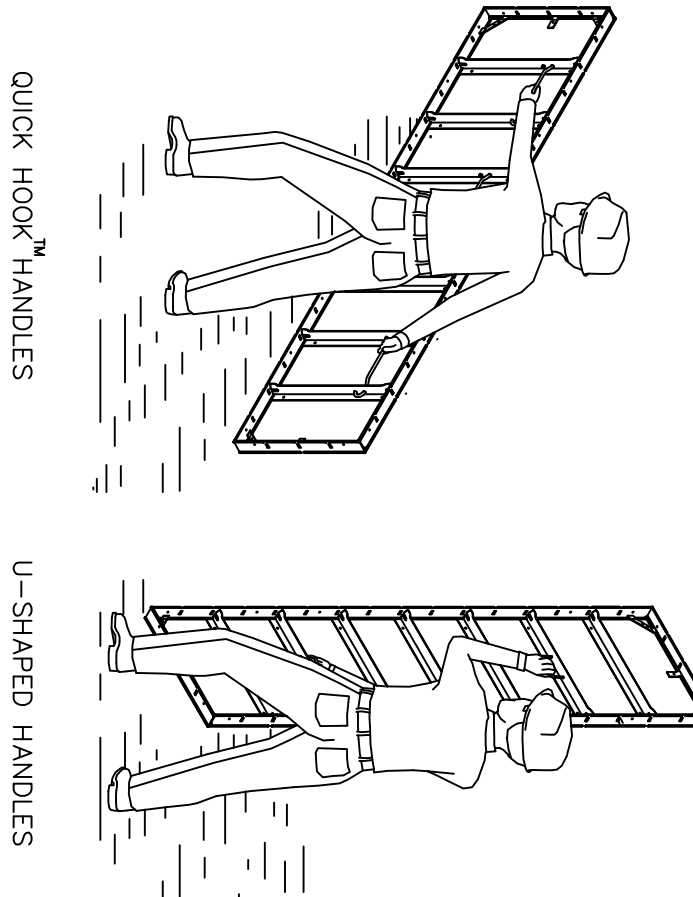

- ANCHOR INSERT – DAYTON/RICHMOND EXPANDED COIL INSERT GALVANIZED 1"-57 3/4"-10" I.D. FERRELL, 4 5/8" LG.
- 3/16" SETBACK
- SETTING PLUG – DAYTON/RICHMOND THERMOPLASTIC PLUG F-74 WITH 3/4"-10" I.D. THERMOS
- ANCHOR BOLT – 3/4"-10" I.D. x 2" LONG ZINC PLATED GRADE 5 WITH FULL LENGTH THREADS
- ANCHOR BOLT MUST BE TIGHTENED TO PREVENT ADJUSTABLE SHEAR WALL BRACKET FROM LOOSENING OR ROTATING.
- SAFE WORKING LOAD = 3000 LBS. AT 3:1 SAFETY FACTOR WHEN INSTALLED AS REQUIRED IN 3500 PSY CONCRETE.
- DO NOT REMOVE BRACKETS UNTIL FORMS ARE STRIPPED AND WEIGHT IS REMOVED FROM BRACKETS.
- THE ADJUSTABLE SHEAR WALL BRACKET HAS AN ADJUSTMENT RANGE DIMENSION "A" FROM 3 1/2" TO 5 7/8".
- FORMS MUST BE BRACED TO SUPPORT ALL OVERTURNING/TIPPING LOADS.
- USE GUIDE BOLT TO GUIDE FORM INTO POSITION. IT LOCKS THROUGH PLATE SLOT WITH WEDGE BOLT.
- SEE FORM LAYOUT DRAWINGS BY SYMONS AND DAYTON/RICHMOND GUIDELINES FOR ANCHOR INSERTS.

TIES

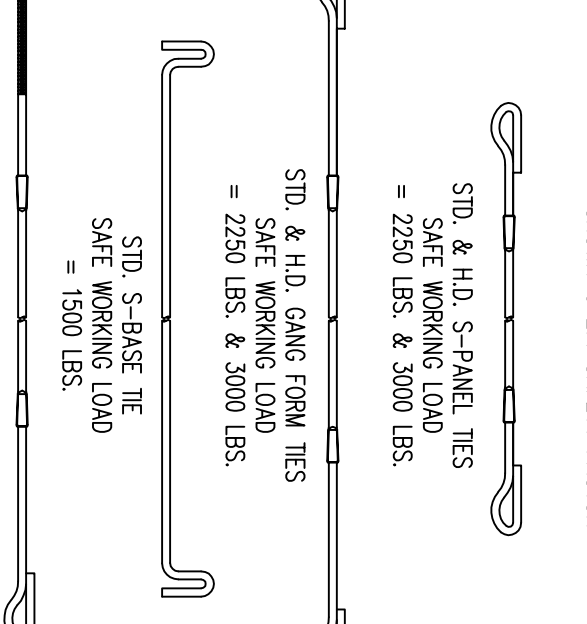

TOGGLE TIES

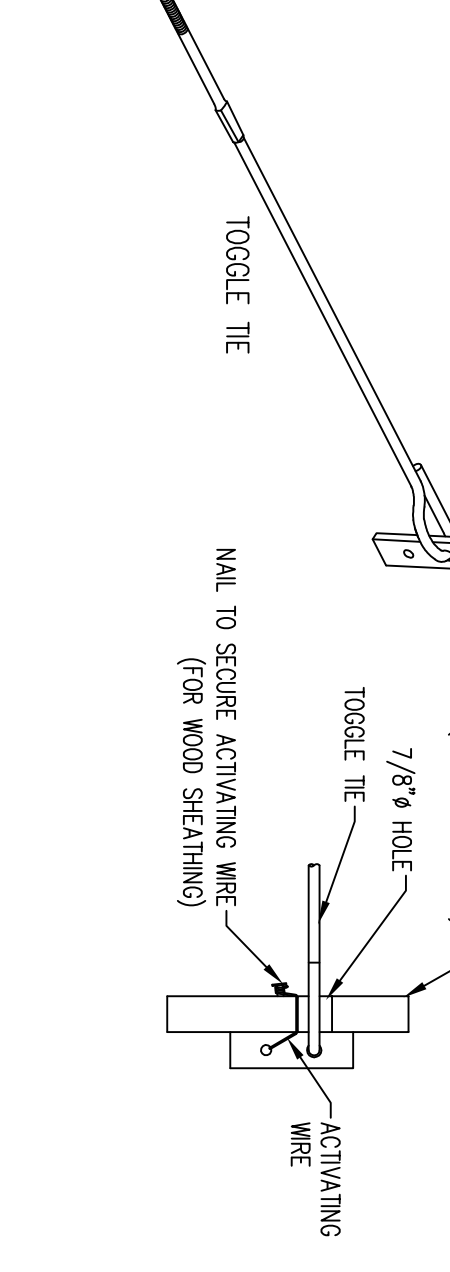

- TOGGLE TIES ARE TO BE WELDED ON BOTH SIZES OF TOGGLE WHEN ATTACHED TO STEEL.
- APPROPRIATE WELDING PROCEDURES MUST BE EMPLOYED FOR SOUND WELD. TOGGLE BASE MATERIAL IS C-1020 HOT ROLLED.
- THE CAPACITY OF TOGGLE TIES ARE DEPENDENT ON THE ADEQUACY OF THE ANCHORAGE BY THE CONTRACTOR.
- TOGGLE TIES PROVIDE FIELD WELD ATTACHMENT TO STEEL PLINGS AS INDICATED IN THE SKETCHES OR FOR TOGGLE ANCHORAGE TO TIMBERS OF STEEL SHEETING AS INDICATED IN THE SKETCH ABOVE. THE LATTER APPLICATION REQUIRES A 7/8" HOLE THROUGH THE SHEATHING MATERIAL AND AN ACTIVATING WIRE TO ASSURE PROPER TOGGLE POSITIONING.
- CARE MUST BE TAKEN TO ASSURE THAT EACH TIE IS TAKING ITS SHARE OF THE LOAD (I.E. ALL NUTS MUST BE EQUALLY TIGHTENED).
- THE RECOMMENDED VERTICAL SPACING IS 12" MAXIMUM ON CENTER FOR ALL WALL HEIGHTS.

PENCIL ROD

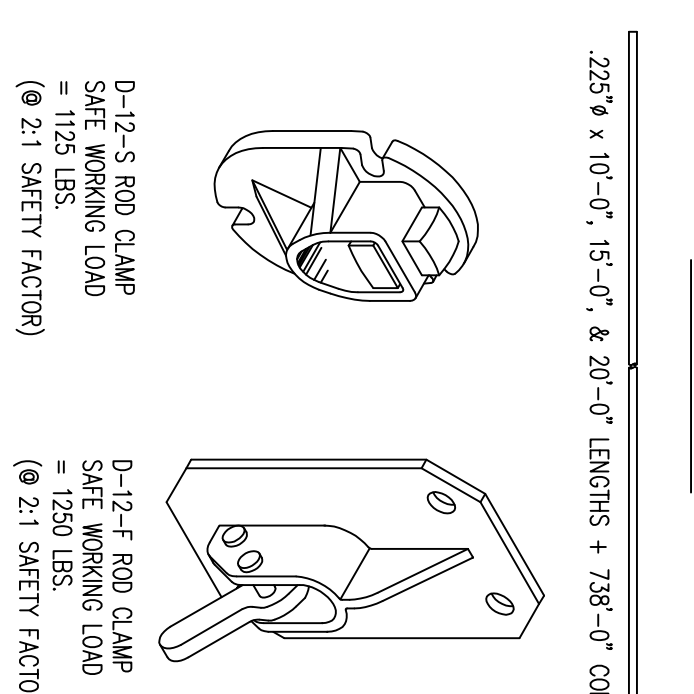

ADJUSTABLE SHEARWALL BRACKET

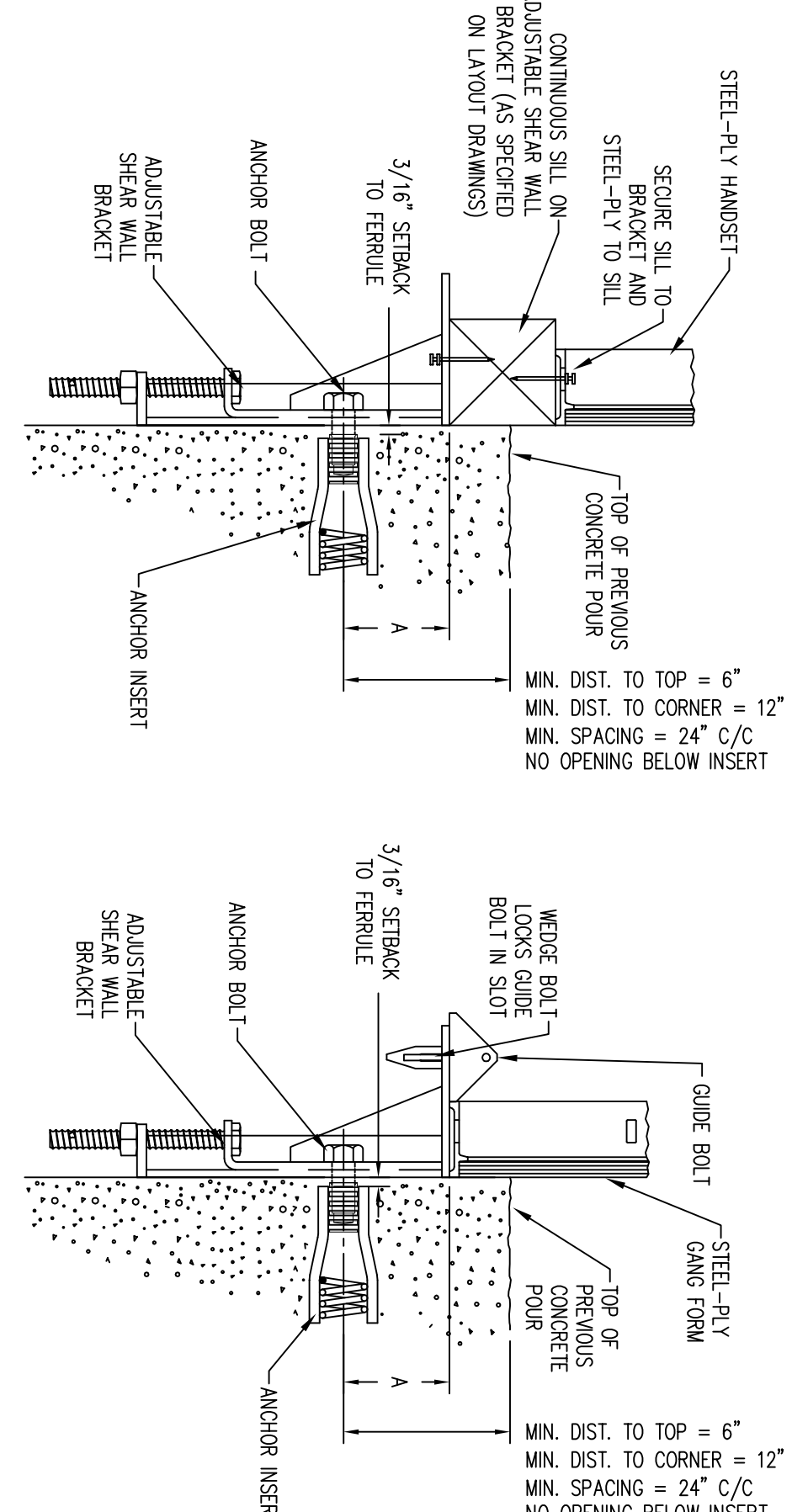

THREADED PANEL TIES

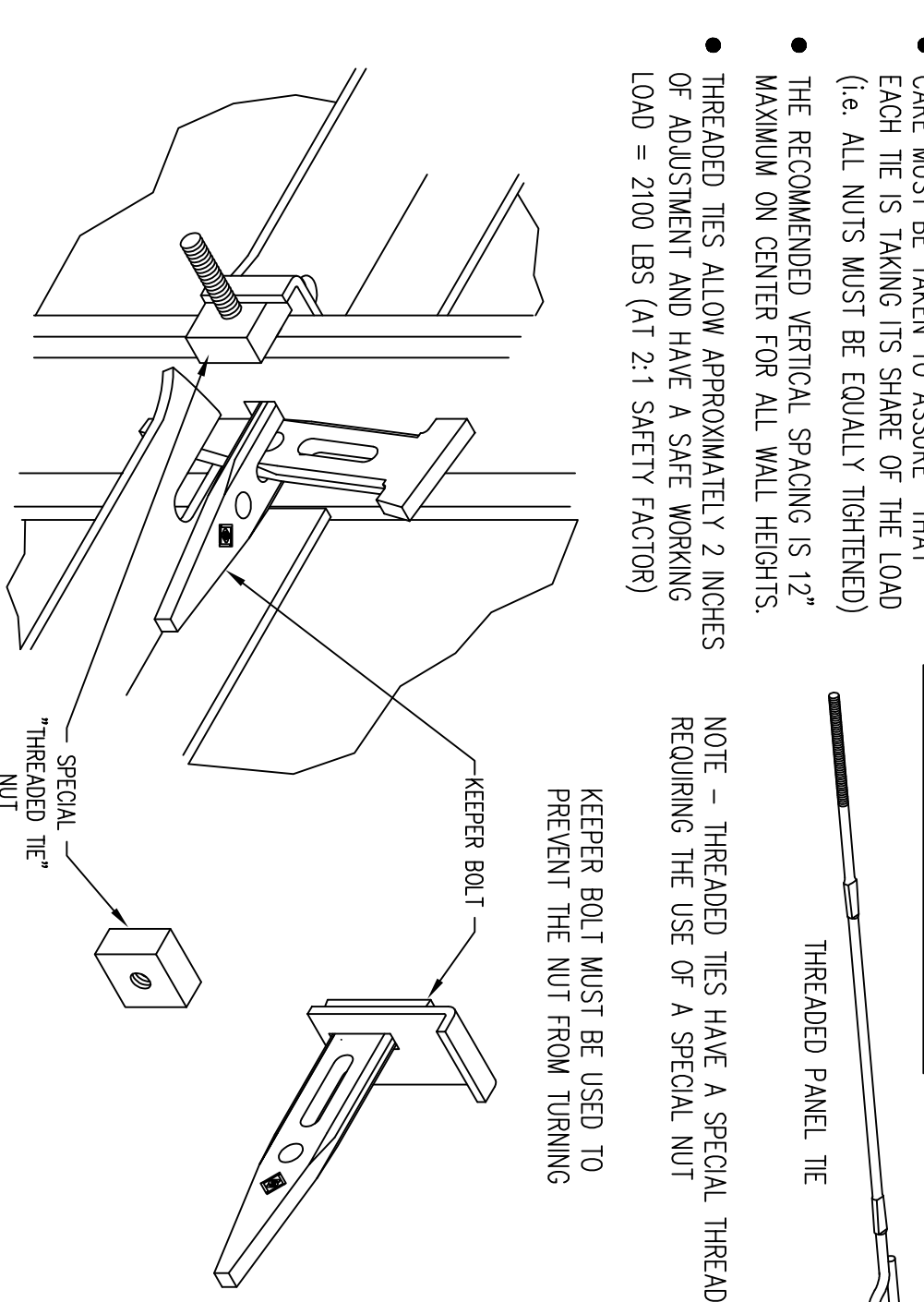

SEE "STEEL-PLY GANG FORM SAFETY APPLICATIONS" FOR ADDITIONAL STEEL-PLY SAFETY INFORMATION

IMPORTANT: SEE SYMONS APPLICATION DRAWINGS, APPLICATION GUIDES AND SAFETY SHEETS FOR ADDITIONAL IMPORTANT INFORMATION, INCLUDING GENERAL NOTES AND LOCAL BRANCH CONTACT INFORMATION.

SYMMONS
BY DAYTON SUPERIOR

2400 E. Arthur Ave.
Eli Grove Village, IL 60007
1-800-800-3652
www.daytonsuperior.com

STEEL-PLY SAFETY APPLICATIONS

FOR	JOB
DATE	LOCATION
DRAWING NO.	SHEET NO.
REV.	

Copyright 2016 Symons Corporation
Symons Safety Sheet Rev. 09-14-14